

8 7 6 5 4 3 2 1

REVISIONS					
ZONE	REV	DESCRIPTION	ECO#	DATE	APPROVED
	A	RELEASED			

UNIT BUILT IN REVERSE

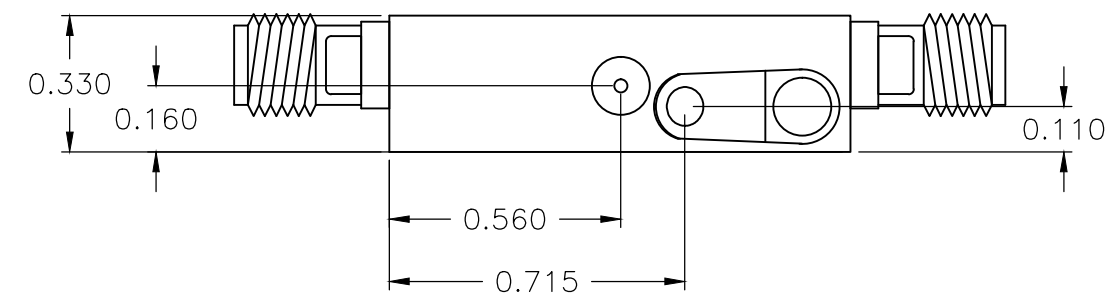
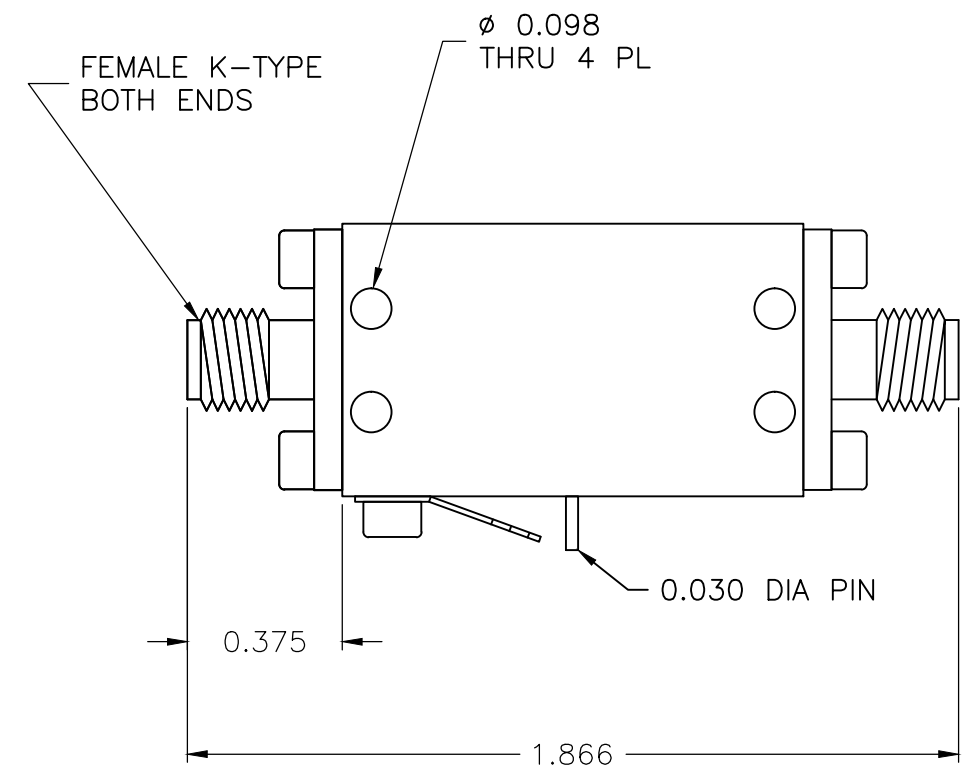
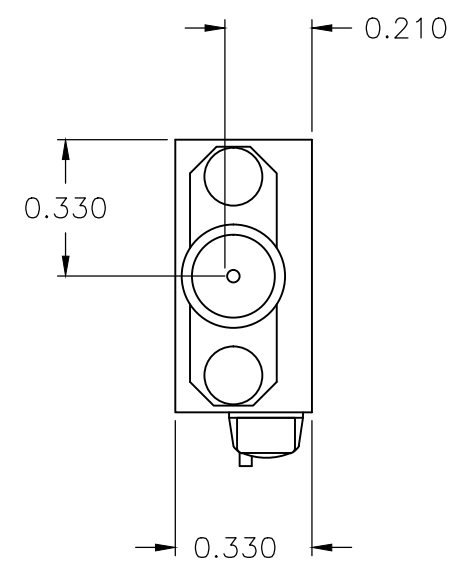
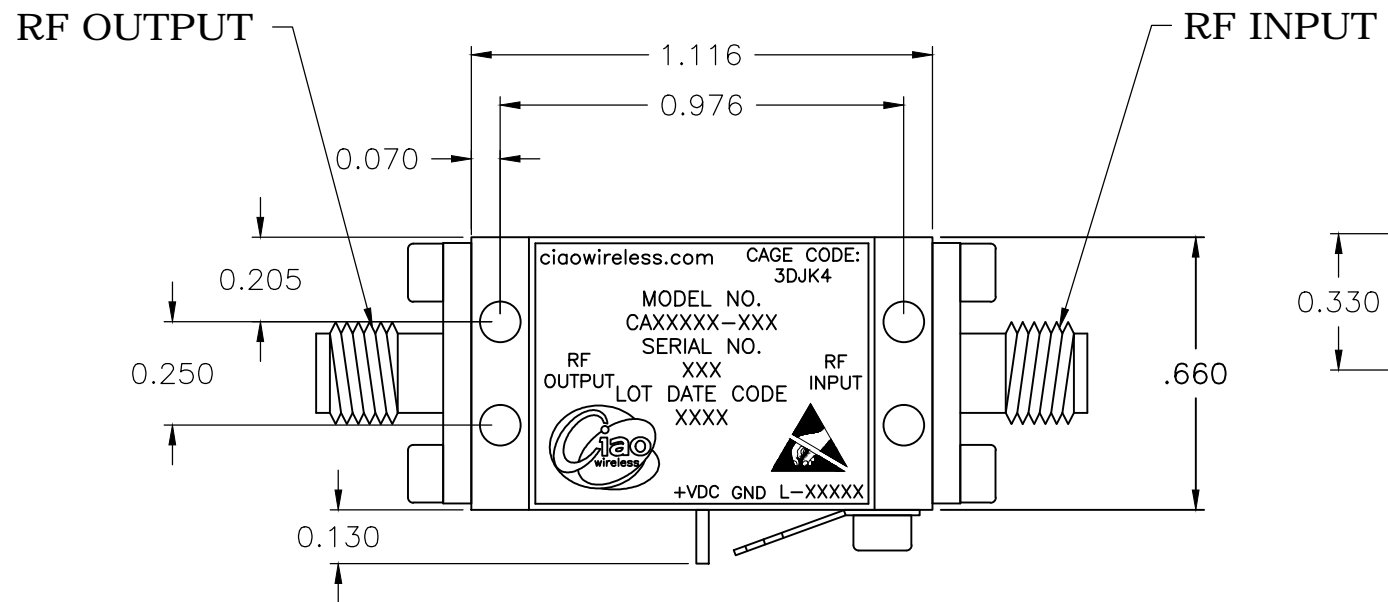

ITEM NO.	QTY REQD	PART OR IDENTIFYING NO.	NOMENCLATURE OR DESCRIPTION	MATERIAL SPECIFICATION
PARTS LIST				
UNLESS OTHERWISE SPECIFIED: DIMENSIONS ARE IN INCHES. TOLERANCES ARE: FRACTIONS DECIMALS HOLES ANGLES ± 1/64 .XX ±.03 .XX ±.03 ± 0°30'			CONTRACT NO.	
MACHINED FINISH: 32 RMS REMOVE BURRS .005 MAX			APPROVALS DATE	
MATERIAL			DRAWN M. BECKNER 7/31/09	
ALUMINUM 6061-T6			CHECKED	
FINISH ELECTROLESS NICKEL PER MIL-C-26074 CLASS 4 GRADE B .0005 ± .0001 MAX			MECHANICAL ENGR	
NEXT ASSY USED ON			ELECTRICAL ENGR	
APPLICATION DO NOT SCALE DRAWING			PRODUCT ASSURANCE	
			PLANNING	
			MANUFACTURING	
SIZE B		CAGE CODE 3DJK4	DWG. NO. 30350-K	REV. A
SCALE 1/1			SHEET 1 OF 1	

CIAO WIRELESS
4000 VIA PESCADOR
CAMARILLO CA, 93012

ALC/X-K2-K ICD AMPLIFIER

30350-K REV. A

8 7 6 5 4 3 2 1